

产品特点：

- ✓ 小体积 127*125*40mm
- ✓ 高可靠性
- ✓ 使用 TS-35/7.5 或 TS-35/15 安装，便于生产维护
- ✓ 效率 92%以上，低损耗
- ✓ 并联冗余功能（可选）
- ✓ 150%的峰值带载能力
- ✓ 内置主动式 PFC 功能，PF>0.9
- ✓ 内置 DC OK 和远程隔离信号输出
- ✓ PCBA 涂覆三防漆
- ✓ 符合环保要求 RoHS6

应用领域：

- ✓ 工业控制
- ✓ 清洁能源
- ✓ 轨道交通
- ✓ 生产制造
- ✓ 对尺寸大小、环境要求十分严酷的场合
- ✓ 对寿命 可靠性要求很高的供电

Features:

- ✓ Small size 127 * 125 * 40mm
- ✓ High Reliability
- ✓ Use TS-35/7.5 or TS-35/15 for easy installation, production and maintenance
- ✓ High efficiency 92%, low power dissipation
- ✓ parallel redundancy (optional)
- ✓ 150% peak load capability
- ✓ Built-in active PFC , PF> 0.9
- ✓ Built-in DC OK and remote isolation signal output
- ✓ Conformal coating on PCBAs
- ✓ Comply with RoHS6

Application:

- ✓ Industrial control
- ✓ Clean energy
- ✓ Rail transit
- ✓ Manufacturing
- ✓ Where the size and environment are very harsh
- ✓ Power supply and distribution systems that require high lifetime and reliability

EDF-240-48

产品规格书

PRODUCT SPECIFICATION

制造安全产品 驱动绿色世界 Power a Safe and Green world

Excellent 卓越 Creative 创造 United 协作



合肥华耀电子工业有限公司
ECU ELECTRONICS INDUSTRIAL CO.,LTD.



微信扫码关注

订购信息 Ordering Information :

设计号 Design NO:

ECU2.939.10655

物料号 Part No :

5.13.70.0709

客户签章

Customer's signature :

日期 DATE :

基本参数 Basic Parameter 1

输入特性 : Input Characteristics : 1

输出特性 : Output Characteristics : 2

环境特性 Environment Characteristics 3

保护功能 Protection Function 3

特殊功能 Specific Function 4

电气安全 Electrical Safety..... 4

电磁兼容 Electromagnetic Compatibility 5

可靠性数据 Reliability 6

结构与安装 Mechanical Installation 6

框架图 Block diagram 6

附件 (安装示意图、降额曲线、典型应用、导轨安装方法) 7

Appendix(Installation Instruction /Derating Curve/Typical Application/Din-rail Installation Method) 7

版本更改记录 Revisions

设计 Designed

田 朗

审核 Checked

王金明

批准 Approved

陈 虎

版本 Rev	日期 Date	更改说明 Description	核准 Approved
A00	2021-12-8	第一次发行 First Issue	扶廷武
A01	2023-3-1	更新降额曲线 Updated derating curve	陈虎
A02	2023-3-31	更新认证 Updated certificated	陈虎
A03	2023-9-7	升级模板 Upgrade the template	陈虎
A04	2025-1-14	添加三防漆 Add Conformal Coating	陈虎

基本参数 Basic Parameter

项目 Item	单位 Unit	规格 Specification	备注 Notes
产品输入输出类型 Input And Output Type		A+D	A) AC-DC; B) AC-AC; C) DC-AC; D) DC-DC
产品工作原理类属 Working Principle		A	A) 开关电源; B) 线性电源 A) Switching power supply; B) Linear power supply
输出电压 Output Voltage	V	48	
额定功率 Total Rated Power	W	240	
峰值功率 Total Peak Power	W	360	5 秒 5 Seconds
效率 Efficiency	%	92	230Vac/50Hz, 额定负载, 0.5h后测试 Run the test after 0.5 hours at full load
功率因数校正 Power Factor Correction		A	A) 主动式 active PFC; B) 被动式 Passive PFC; C) 无 No
纹波&噪声 Ripple Noise	mVp-p	120	详见备注 See remarks
产品认证标志 Product Certification Mark		1、6	0 无、1 CE、2 CCC、3 CQC、4 TUV、5 UL、6 CB、7 TUVul、8 CSA、 9 FCC、10 KC、11 GL、12 ATEX、13 IECEx、14 CUL、15 其它 others

1. 输出纹波噪声测试条件/DC output ripple & noise test conditions:

1) 示波器须设置在 20M 赫兹带宽/Oscilloscope should be limited at 20MHZ bandwidth;

2) 将 0.1uF 的陶瓷电容和 47uF 的电解电容并联在线材末端/ Connect 0.1uF ceramic capacitors and 47uF electrolytic capacitors in parallel at the end of the wire;

3) 使用 300mm 的双绞线连接电源和负载/ Connect the load and power supply with a 300mm twisted pair;

4) 在负载端进行测试/ Test on the load side;

5) 若无特殊说明, 以上规格参数均在输入电压范围为 85~264Vac, 温度范围 25°C 的环境下测量。/ Unless otherwise specified, the above specifications are measured in the input voltage range of 85~264Vac and the temperature range of 25 °C.

2. “/” : 不符合项 “/” : Non-conformance term;

输入特性 : Input Characteristics :

项目 Item	单位 Unit	最小值 Min	额定值 Rated	最大值 Max	备注 Notes
输入电压类型 Input Voltage Type			B+D		A) 三相供电; B) 单相供电; C) 双相供电; D) 直流供电; E) 其它不规则供电 A) Three-phase; B) Single-phase; C) Dual phase; D) DC power supply; E) Other power supply
输入电压 Input Voltage	Vac	85	115/230	264	参考输出降额曲线 Refer to output derating curve.
	Vdc	90	310	370	
输入频率 Input Frequency	Hz	47	50	63	
输入电流 Input Current	A			1.3	230Vac 满载 Full load
				3.8	115Vac, 满载 Full load.
输入冲击电流 Inrush Current	A			20	115Vac, 满载, 冷机启动 Full load. cold start.
				30	230Vac, 满载, 冷机启动 Full load. cold start.
输入冲击电流方案 Inrush Current Mode			B		A) 主动式 Active; B) 被动式 Passive; C) 单电阻 Only Resistance; D) 无 NO
功率因数 Power Factor	/	0.95	/	/	115Vac, 满载 Full load.
		0.90			230Vac, 满载 Full load.
空载损耗 No-Load Consumption	W			5	230Vac, 空载 No load @ Vout=48V

输入保险
Input Fuse

T5A/250Vac

"/": 不符合项 " / ": Non-conformance term;

输出特性 : Output Characteristics :

项目 Item	单位 Unit	最小值 Min	典型值 Typ	最大值 Max	备注 Notes
标准输出电压 Output Voltage	Vdc		48		
输出电压可调范围 Output Voltage Adjustable Range	Vdc	46		56	
额定输出电流 Rated Output Current	A	0		5	@48V输出 Output@48V
峰值输出电流1 Output Peak Current1	A			5.5	@48V输出Output@48V
峰值输出电流2 Output Peak Current2	A			7.5	@48V输出Output@48V
峰值功率持续时间 Peak Power Duration	s			5	5秒后, 电源将进入恒流模式, 详见峰值功率图及限流特性图 The power supply will enter constant current mode after 5 Seconds; For details see Boost Characteristic and Current Limiting Characteristic
峰值电流持续时间 Output Peak Current Duration	s			5	5秒后, 电源将进入恒流模式, 详见峰值功率图及限流特性图 The power supply will enter constant current mode after 5 Seconds; For details see Boost Characteristic and Current Limiting Characteristic
负载调整率 Load Regulation	%	/	/	+/-1	230Vac ,0% ~ 100% load最小负载到额定负载 Min load to rated load
输入电压调整率 Line Regulation	%			+/-0.5	85~264Vac 额定负载 Rated load
温度调整率 Temperature Regulation	%			+/-0.07	+/-0.07% @ 0°C~+60°C; +/-1% @ -25°C~0°C&+60°C~+70°C; +/-2.5% @ -40°C~-25°C;
电压误差 Voltage Tolerance	%			+/-2	-25°C~+70°C
开机延迟时间 Setup Time	s			2	115Vac&230Vac 100% Load 额定负载 Rated load
上升时间 Rise Time	ms			100	输出从10%上升到90%的时间 The time taken while output voltage increased from 10% to 90%
保持时间 Hold Up Time	ms	20			115Vac, 满载Full load
	ms	20			230Vac, 满载Full load
过冲响应 Overshoot Response (O/P Voltage)	%			+/-5	开关机时 Power on/off
负载动态 Load Dynamic Response	%			+/-5	设定周期20ms,升降电流0.1A/μs,在10%~90%负载 Setting period 20ms. Rising and falling current 0.1A/μs@ 10%~90% load
串联功能 Series Connection	V				详见附件 See Appendix
并联冗余功能 Parallel Connection	A				详见附件 See Appendix

"/": 不符合项 " / ": Non-conformance term;

环境特性 Environment Characteristics

项目 Item	单位 Unit	最小值 Min	典型值 Rated	最大值 Max	备注 Notes
温度 Temperature	°C	-25	25	70	工作温度 Operation Temperature ; 50°C~70°C以上需降额使用, 参考降额曲线; -40°C启动; Derated@50°C~70°C, refer to derating curve; Start up@-40°C
		-40	25	85	贮藏温度 Storage Temperature
相对湿度 Humidity	RH	5%		95%	工作湿度 Operation Humidity
		5%		95%	贮藏湿度 Storage Humidity
振动 Vibration		幅度<15Hz, ±2mm (IEC 60068-2-6) /15Hz...150Hz, 2.3g, 90分钟 < 15Hz, amplitude ±2.5mm(acc. to IEC 60068-2-6) / 15Hz ... 150Hz, 2.3g, 90 min.			
冲击 Impact		30g, 各个方向 (IEC 60068-2-27) 30g, each direction(acc. to IEC 60068-2-27)			
海拔高度 Altitude		≤3000m, 3000m以上降额使用, 15%load/Km, 最高海拔5000m ≤3000m, derated over 3000m, 15% load/Km, max altitude 5000m			
冷却方式 Cooling Mode		空气自然冷却 Air Cooling			
防护等级 IP Level		IP20			
污染等级 Pollution Level		PD2			
RoHS环境指令		符合 Compliant			
阻燃等级 (外壳) Flame Rating(Case)		UL94V-0			
船级社 DNV GL		/			
三防漆 Conformal Coating		PCBA涂覆三防漆 Conformal Coating on PCBAs			

“/”：不符合项 “/”：Non-conformance term;

保护功能 Protection Function

项目 Item	技术要求 Technical Requirement	恢复方式 Recovery Mode	保护方式 Protection Mode	备注 Notes
输出短路保护 Output Short Circuit Protection	电源无损坏, 关闭输出电压 Power supply no damaged, shut down O/P voltage.	A	B	恢复方式 Recovery mode : A) 自动恢复 Auto recovers; B) 重启恢复 Restart;
输出过流保护 Output Over Current Protection	155%~165% @ Io	A	B	
输出过压保护 Output Over Voltage Protection	125~150% @ Vo	A	C	保护方式 Protection mode : A) 恒功率 Constant power; B) 恒电流 Constant current; C) 输出掉电 Output voltage drop;
过温保护 Over Temperature Protection	关闭输出电压 Shut Down O/P Voltage.	A	C	

“/”：不符合项 “/”：Non-conformance term;

特殊功能 Specific Function

项目 Item	技术要求 Technical Requirement
面板显示 Panel Display	当输出指标正常时，绿色LED常亮/Output Voltage \geq 43.2V，Green LED is always on;
远程信号 Remote Signal	与输出隔离，常开触点；当输出电压大于85%时，DC OK为低阻抗 \leq 50m Ω ，最大耐受直流30 V / 1 A/ Normally open contact, isolated output, ; Output voltage \geq 85%V，DC OK is a low impedance \leq 50m Ω ，Max DC 30 V / 1 A

"/"：不符合项 "N"：Non-conformance term;

电气安全 Electrical Safety

项目 Item	测试方法 Test Method	测试条件 Test Conditions	备注 Notes
高压测试 Hi-pot Test	输入-输出 I/P-O/P	3000Vac. 60S, \leq 15mA	
	输入-大地 I/P-PE	1500Vac. 60S, \leq 15mA	
	输出-大地 O/P-PE	700Vdc.60S, \leq 1mA	
绝缘阻抗 Withstand Resistance	输入-输出 I/P-O/P		500VDC. \geq 5M Ω
	输入-大地 I/P-PE		500VDC. \geq 5M Ω
	输出-大地 O/P-PE		500VDC. \geq 5M Ω
泄露电流 Leakage Current	L、N-外壳/L、N-Case		3.5mA Max
	L、N-PE/L、N-PE		3.5mA Max
接地阻抗 PE Resistance	PE-外壳/PE-Case		< 0.1Ohm
过电压等级 Overvoltage category	III, II		III (IEC 61010-1, IEC 61010-2-201, EN 62368-1, EN 61558-2-16) II (EN 62368-1, EN 60335-1)
电气设备安全等级类属 Electrical Equipment Safety Class	A		A)一类设备Class I ;B)二类设备Class II;C)三类设备 (最高标称电压不超过50Vac或120VDC，以及不属于AB) Class III(The maximum nominal voltage does not exceed 50Vac or 120VDC, and is not part of A,B); EN 61140, GB/T17045
安规标准 Safety Standard	/		UL1310 (CLASS II产品 Product)
	/		EN62368-1, GB4943.1资讯类Information technology
	/		EN60601-1, GB9706.1医疗类Medical
	/		EN61347-1, EN61347-2-13, GB7000.1, GB19510.1, GB 19510.14 灯具类Lamp
	/		EN60335-1, EN60335-2-29, GB4706.1 家电类Household appliances
/		EN61010, GB4793.1工控类Industrial control	

1) “/”：不符合项 "N"Non-conformance;

电磁兼容 Electromagnetic Compatibility

项目 Item	测试方法 Test Method	测试条件 Test Conditions	
静电ESD Electrostatic Discharge	IEC 61000-4-2 GB17626-2	Criteria A ; Air Discharge: ±8kV ; Contact Discharge: ±4kV	
射频辐射 Radiated Field	IEC 61000-4-3 GB17626-3	Criteria A ; 80MHz-6GHz, 10Vrms, 80% modulation (1kHz) ;	
脉冲杂讯 Electrical Fast Transient / Burst	IEC 61000-4-4 GB17626-4	Criteria A ; ±4kV	
雷击 Surge	IEC 61000-4-5 GB17626-5	Criteria A ; Common Mode: 4kV ; Differential Mode: 2kV	
射频传导 Conducted Emission	IEC 61000-4-6 GB17626-6	Criteria A ; 150KHz-80MHz, 10Vrms , 80% modulation (1kHz)	
电源磁场 Power Frequency Magnetic Fields	IEC 61000-4-8 GB17626-8	30A/meter, Criteria B	
脉冲磁场抗扰度试验 Impulse Magnetic Field Immunity Test	IEC 61000-4-9 GB17626-9	300A/meter, Criteria B	
阻尼振荡磁场抗扰度试验 Damped Oscillatory Magnetic Field Immunity Test	IEC 61000-4-10 GB17626-10	100A/meter 100KHz and 100MHz, Criteria B	
电压瞬断 Voltage Dips And Interruptions	IEC 61000-4-11 GB17626-11	Voltage Dips >95% reduction,0.5 period	Criteria A
		Voltage Dips >30% reduction,25 period	Criteria B
		Voltage interruptions >95% reduction,250 period	Criteria B
低能量脉冲 Low Energy Pulse Test (Ring Wave)	IEC 61000-4-12 GB17626-12	Criteria B Common Mode:2kV ; Differential Mode: 1kV	
谐波 Harmonic Current Emission	IEC/EN 61000-3-2 GB17625-1	Class A	
电磁耐受标准 Immunity Generic Standards		EN 55024,GB17618资讯类Information technology	
	/	EN55014-2家电类Household appliances	
	/	EN60601-1-2医疗类Medical	
	/	EN61547灯具类Lamps	
		EN61000-6-1,EN50082-1,GB/T17799-1轻工业环境Light industry environment	
传导和辐射通用标准 CE&RE		EN 61000-6-2,EN55082-2,GB/T17799-2工业环境Industry environment	
	/	GB9254, CISPR 32, EN 55032 : Class B 资讯类Information technology	
	/	GB4824, CISPR 11, EN 55011 : Class B 医疗类Medical	
	/	GB17743 , EN55015 , CISPR15 : Class B 灯具类Lamps	
		GB4343-1, CISPR14 , EN55014-1 : Class B 家电类Household appliances	
	EN 61000-6-3 , FCC Title 47, EN55011 : Class B 工控类Industrial control		
电压波动和闪烁 Voltage Fluctuation and Flicker		IEC/EN 61000-3-3 , GB17625.2 ; Criteria B	

- 标准A：规格界限内正常性能Criteria A: Normal performance within the specification limits;
- 标准B：可自行恢复的临时性退化或功能丧失Criteria B: Temporary degradation or loss of function which is self-recoverable;
- 标准C：不可自行恢复的临时性退化或功能丧失，必须重新启动后才能恢复正常工作Criteria C:Need to restart the power supply, to return to normal work;
- 标准D：永久性退化或功能丧失，需要更换零部件或维修人员介入Criteria D:Permanent degeneration or loss of function;
- 不对称：共模（线对地）Asymmetrical: Common mode (Line to earth);
- 对称：差模（线对线）Symmetrical: Differential mode (Line to line);
- “/”：不符合项“/”Non-conformance;
- 电源应视为系统内元件的一部分，需结合终端设备进行EMC确认Power should be considered part of the element within the system, to be combined with the terminal device EMC acknowledgment;

可靠性数据 Reliability

项目 Item	数据 Data	测试条件 Test Conditions
产品老化 Burn-in	100%	230Vac, 满载Full load, 40°C ±5°C, 4小时Hours
平均无故障时间 MTBF	370K hrs Min	230Vac, 满载Full load, 25°C, MIL HDBK 217F

“/”：不符合项 / "Non-conformance;

结构与安装 Mechanical Installation

项目 Item	数据 Data	备注 Note
尺寸mm (长宽高) Size	127 * 125* 40	材质：铝；Case material：AL
重量Kg Weight	0.74	
安装方式 Installation	导轨式安装 Mounted On 35mm DIN Rails	TS-35/7.5或TS-35/15 EN 60715
最小间距 Space	上下(Above/Below)：45mm；左右(Left and right side): 0mm,5mm With a Heat Source	
输入端子 Input Terminal	脚距7.5mm, 3位 Pitch=7.5mm, 3pin	直插式连接Push-In Terminal;
	7 PIN---L	硬导线横截面Hard wire cross section 0.2 mm ² ... 4 mm ² ;
	8 PIN---N	柔性导线横截面Flexible wire cross section 0.2 mm ² ... 2.5 mm ²
	9 PIN---FG	横截面Cross section AWG 24 ... 12 剥线长度Strip length 10 mm
输出端子 Output Terminal	脚距5mm, 4位/Pitch=5mm, 4pin	
	1 PIN---V+	直插式连接Push-In Terminal;
	2 PIN---V+	硬导线横截面Hard wire cross section 0.2 mm ² ... 4 mm ²
	3 PIN---V-	柔性导线横截面Flexible wire cross section 0.2 mm ² ... 2.5 mm ²
	4 PIN---V-	横截面Cross section AWG 24 ... 8
	5 PIN---DC OK	剥线长度Strip length 14mm-15 mm
	6 PIN---DC OK	

框架图 Block diagram

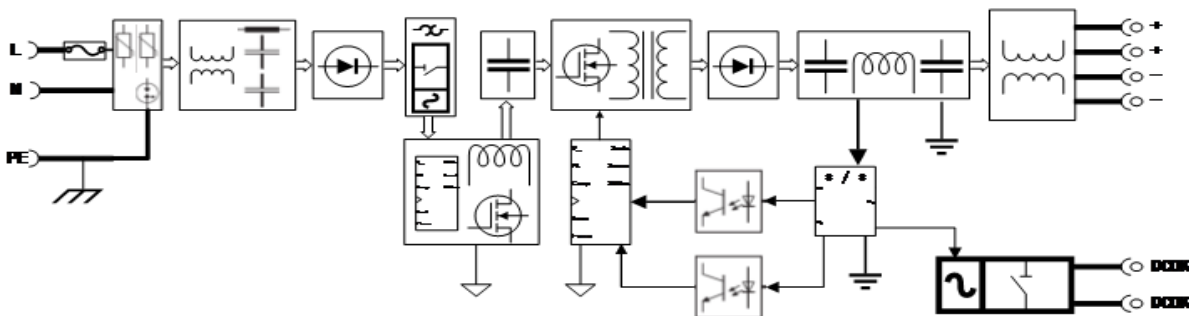

附件 (安装示意图、降额曲线、典型应用、导轨安装方法)

Appendix(Installation Instruction /Derating Curve/Typical Application/Din-rail Installation Method)

1. 产品装配示意图 Product assembly

说明:

Note:

A: 产品名称特性示意, 具体参数依照规格书。

A: Refer to product specifications.

B: 建议扭矩: M3.0 螺钉 $0.4 \text{ N} \cdot \text{m}$; M4.0 螺钉 $0.6 \text{ N} \cdot \text{m}$。

B: Suggested tightening torque: M3.0 screw $0.4 \text{ N} \cdot \text{m}$; M4.0 screw $0.6 \text{ N} \cdot \text{m}$.



Install rail / 安装轨道: TS35/7.5 or TS35/15

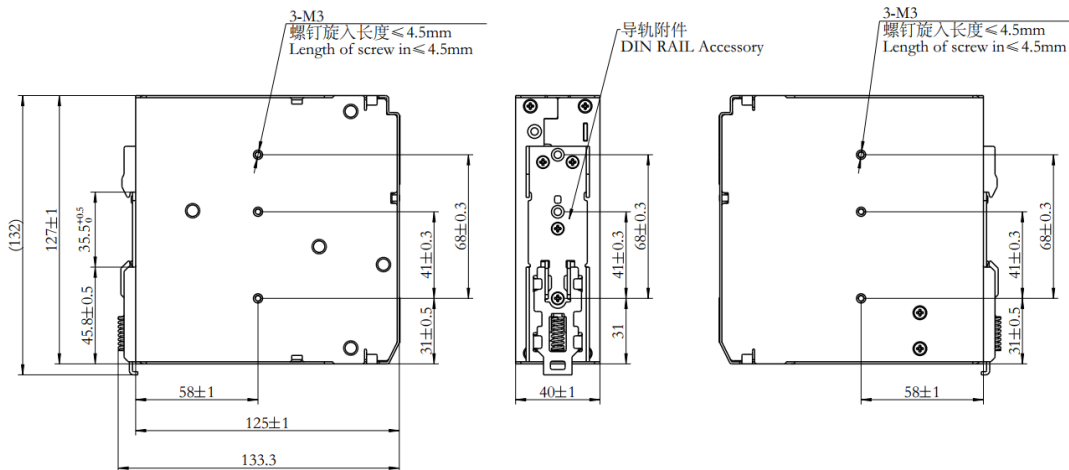

2. 降额曲线 Derating Curve:



图1：输入电压下输出功率降额曲线
Fig1: Output Power Derating curve depending on Input Voltage



图2：环境温度和输入电压下输出功率降额曲线
Fig2: Output Power Derating curve depending on Ambient Temperature and Input Voltage

总输出功率的降额计算:

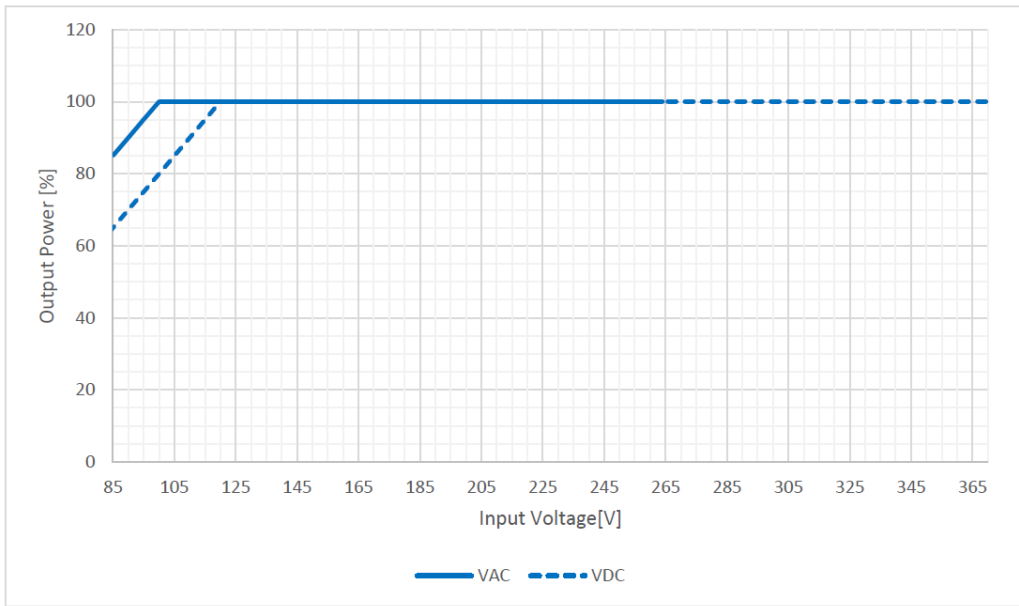
Calculation of total output power derating:

输出功率 (%) = [图1(%) × 图2(%)] / 100

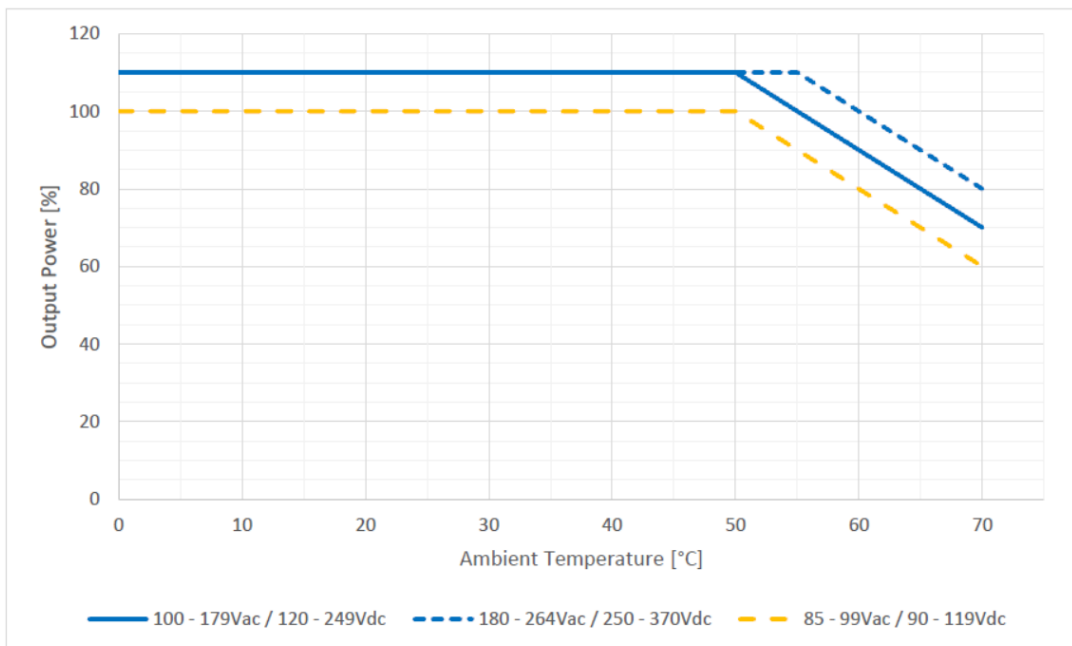
Total Output Power [%] = (Fig1 Output Power [%] * Fig2 Output Power [%]) / 100

对于图2，仅在看降额曲线时按5.5A输出电流，其他正常情况下按5A

For Fig2: Run 5.5A only when looking at the Derating curve, other normal conditions run 5A.

3. 限流特性 Current Limiting Characteristic



图1：正常输出电压下，正常和峰值工作时的限流曲线
 Fig 1: Current limiting curve in normal and Boost operation depending on the nominal output voltage



图2:短路情况下，非重复的峰值电流特性
 Fig 2: Non-repetitive Boost during continuous short circuit

4. 峰值功率特性 Boost Characteristic

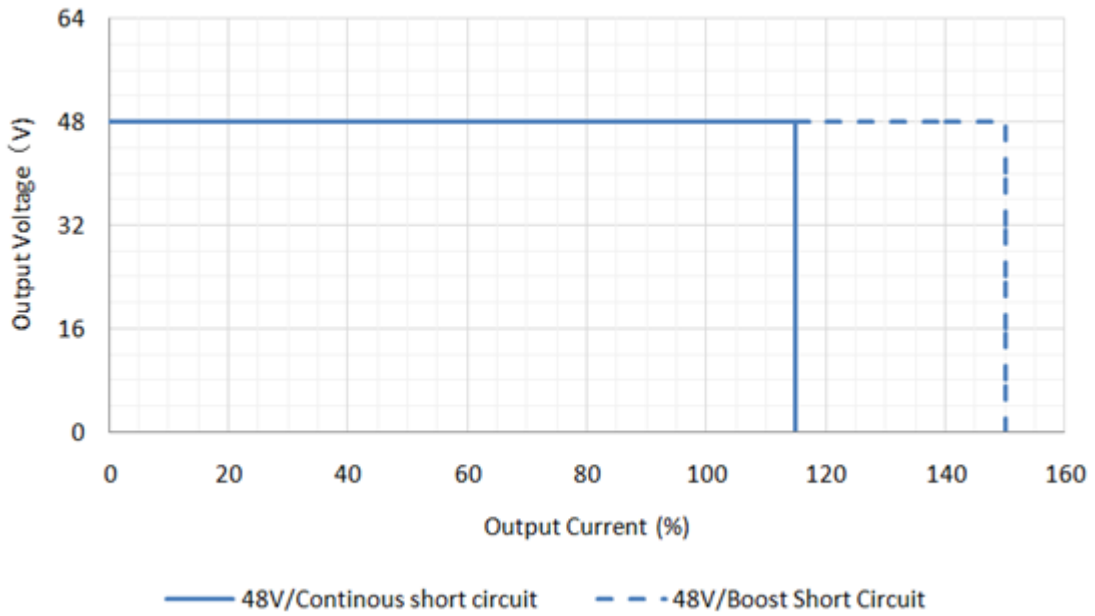

图1: 环温50°C情况下 (80%→150%输出功率), 峰值功率时间5s

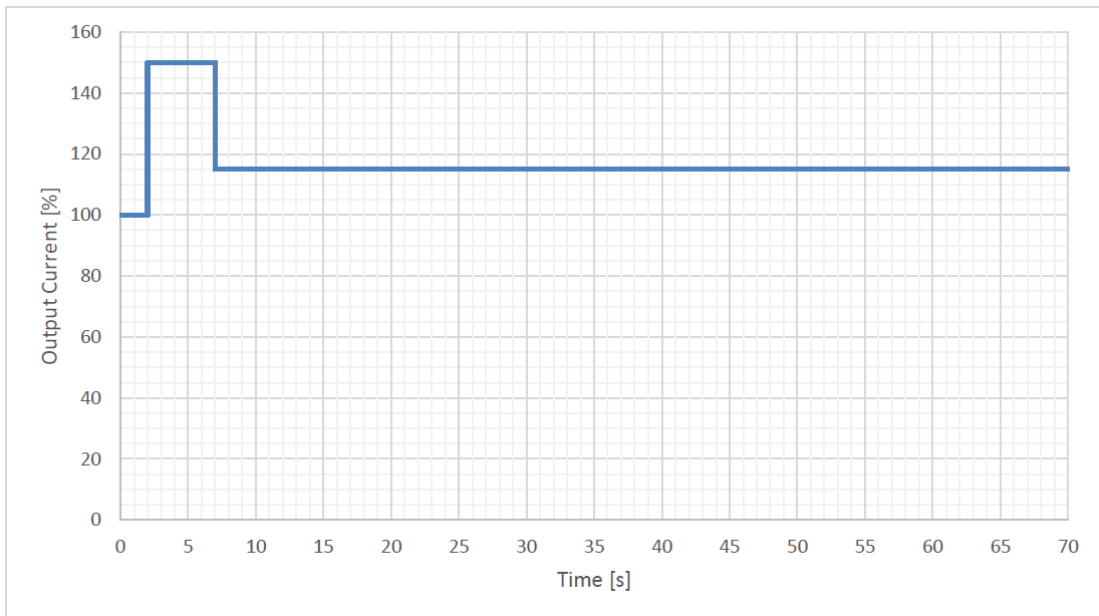
Fig 1: Timing between two Boost events for 5s at 50°C ambient (80%→150% output power)

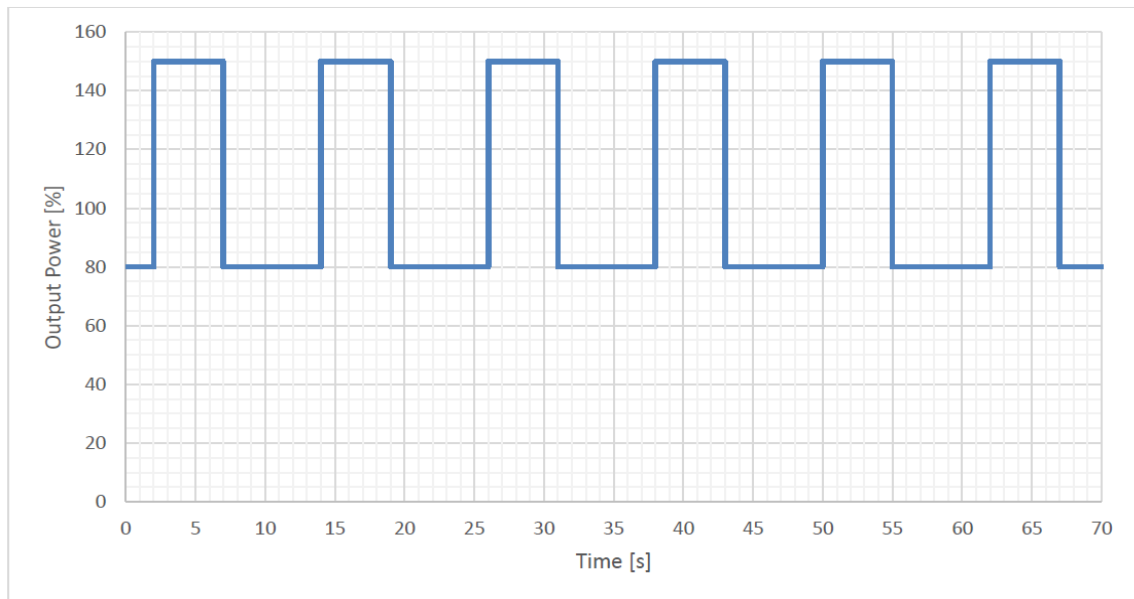

图2: 环温50°C情况下 (100%→150%输出功率), 峰值功率时间5s

Fig 2: Timing between two Boost events for 5s at 50°C ambient (100%→150% output power)

5. 典型应用 Typical Application:

3.1 串联接线图 Series Operation Connection Diagram:

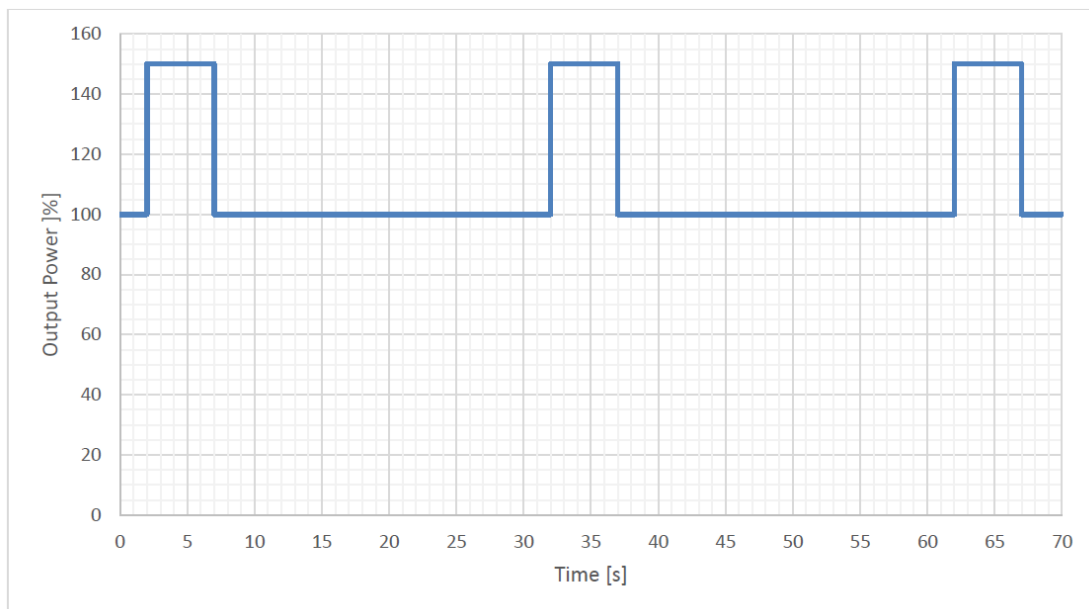
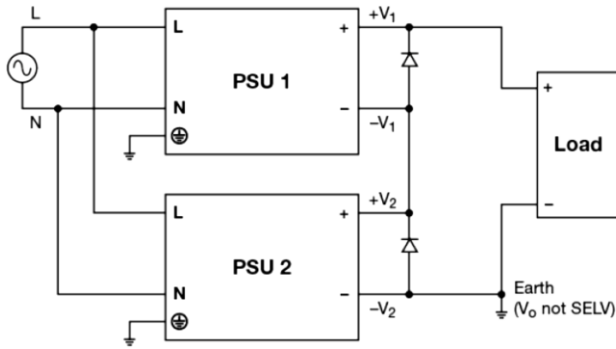

3.2 1+1 冗余接线图 1+1 Redundancy Connection Diagram

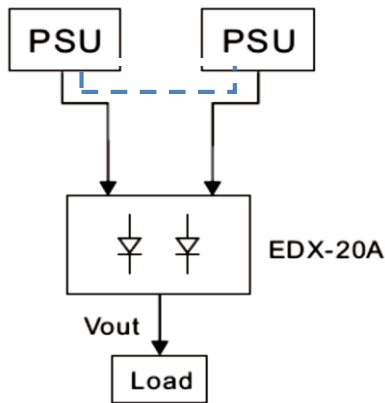

3.3 1+N 冗余接线图 1+N Redundancy Connection Diagram:

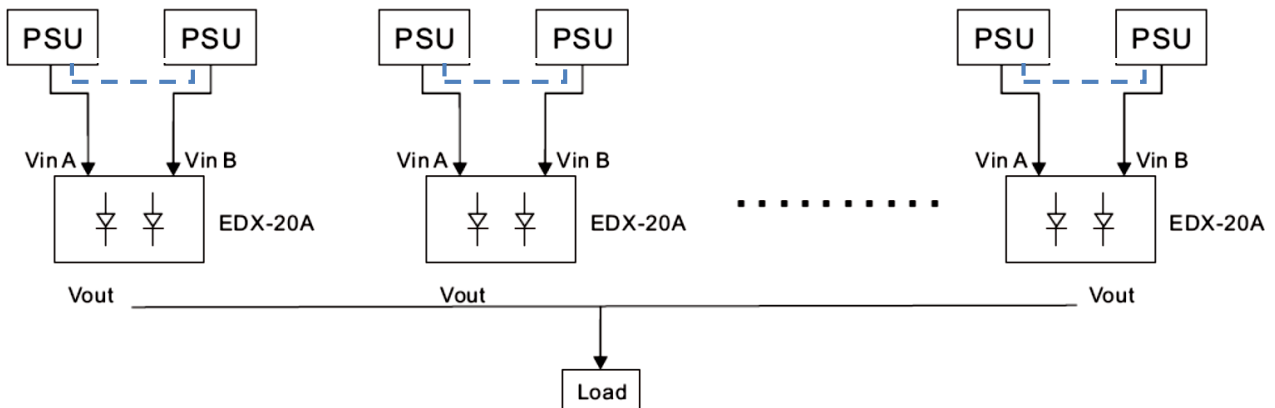

3.4 可靠性系统构建图 Reliability system:

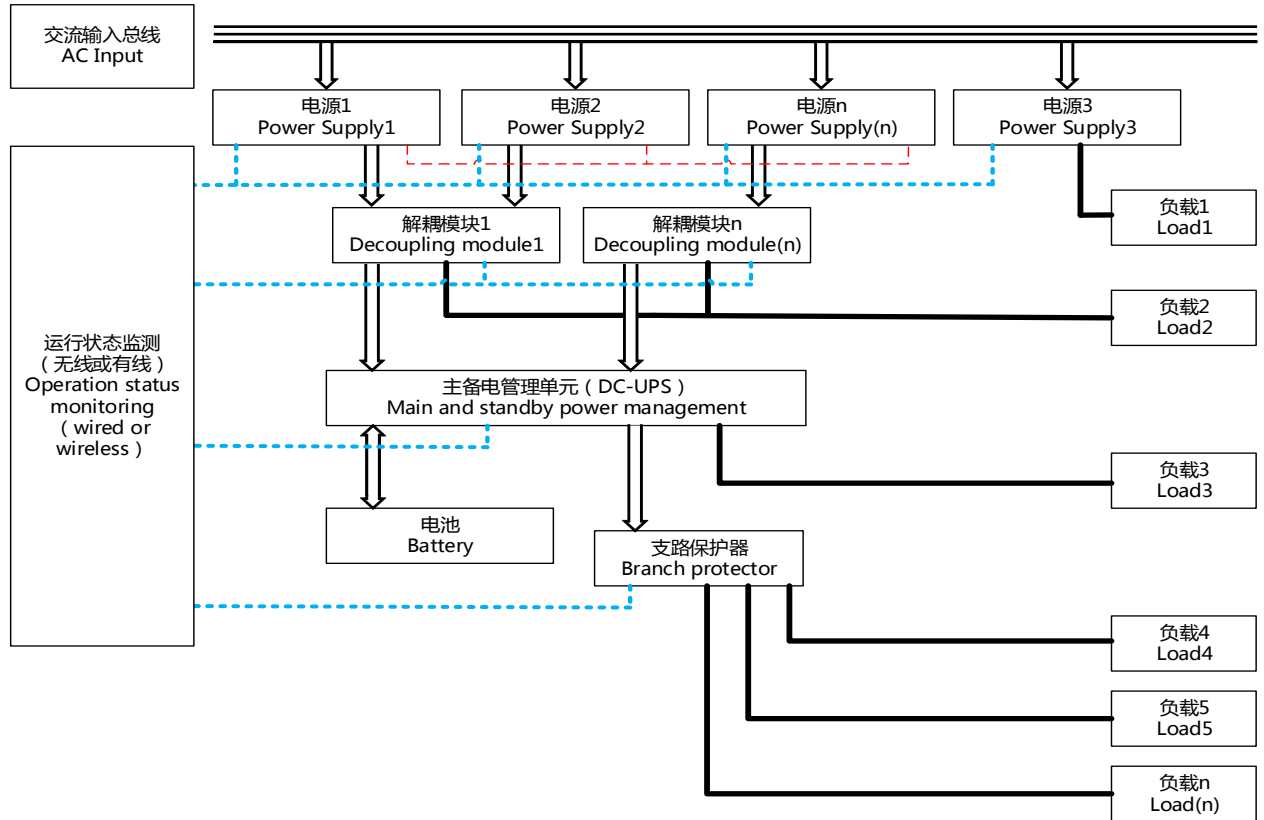

6. 导轨安装方法 Din Track Mounting:

- (1) To mount the Block on a DI track, hook portion (A) of the Block onto the track and press the Block in direction (B).
 安装：将(A)部分挂入导轨，朝(B)方向按压卡入导轨

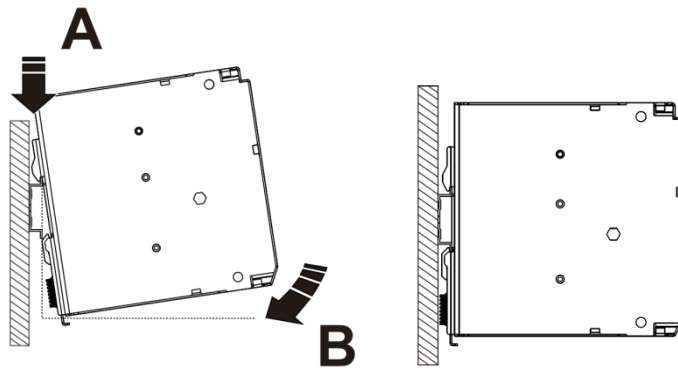

- (2) To dismount the Block, pull down portion (C) with a flat-blade screw-driver and pull out the Block.
 拆卸：用平口螺丝刀下拉(C)部分拆卸电源

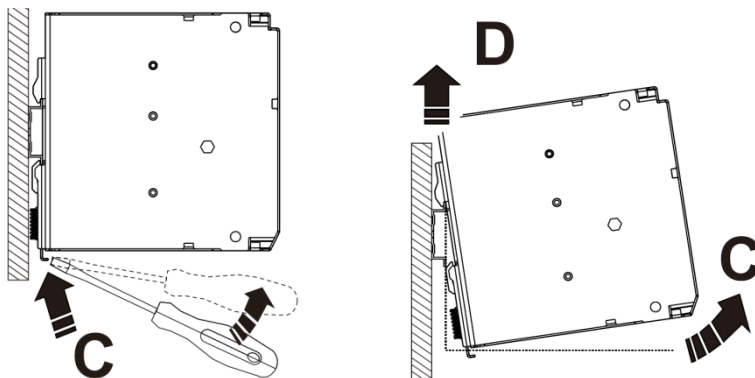

(3)通用壁挂式安装图 Mounting the universal wall adapter

