

产品特点:

- ✓ 小体积 127*115*35mm
- ✓ 高可靠性
- ✓ 使用 TS-35/7.5 或 TS-35/15 安装, 便于生产维护
- ✓ 效率 88% 以上, 低损耗
- ✓ 自然风冷, 满载工作
- ✓

Features:

- ✓ Small size 127 * 115 * 35mm
- ✓ High Reliability
- ✓ Use TS-35/7.5 or TS-35/15 for easy installation, production and maintenance
- ✓ High efficiency 88%, low power dissipation
- ✓ Natural air cooling ,full-load operation

应用领域:

- ✓ 工业控制
- ✓ 清洁能源
- ✓ 轨道交通
- ✓ 生产制造

Application:

- ✓ Industrial control
- ✓ Clean energy
- ✓ Rail transit
- ✓ Manufacturing

EDG-75-24

产品规格书

PRODUCT SPECIFICATION

制造安全产品 驱动绿色世界 Power a Safe and Green world

Excellent 卓越 Creative 创造 United 协作



合肥华耀电子工业有限公司
ECU ELECTRONICS INDUSTRIAL CO., LTD.



微信扫描关注

订购信息 Ordering Information:

设计号 Design NO:

ECU2.939.10614

物料号 Part No:

5.13.70.0670

客户签章

Customer's signature:

日期 DATE:

基本参数 Basic Parameter 1

输入特性: Input Characteristics: 1

输出特性: Output Characteristics: 2

环境特性 Environment Characteristics 2

保护功能 Protection Function 3

特殊功能 Specific Function 3

电气安全 Electrical Safety 3

电磁兼容 Electromagnetic Compatibility 4

可靠性数据 Reliability 4

结构与安装 Mechanical Installation 5

框架图 Block diagram 5

附件 (安装示意图、降额曲线、典型应用、导轨安装方法) 6

Appendix(Installation Instruction /Derating Curve/Typical Application/Din-rail Installation Method) 6

版本更改记录 Revisions

版本 Rev	日期 Date	更改说明 Description	核准 Approved
A00	2024-07-19	第一次发行 First Issue	陈虎

设计 Designed

田 朗

审核 Checked

王金明

批准 Approved

陈 虎

基本参数 Basic Parameter

项目 Item	单位 Unit	规格 Specification	备注 Notes
产品输入输出类型 Input And Output Type		A+D	A) AC-DC; B) AC-AC; C) DC-AC; D) DC-DC
产品工作原理类属 Working Principle		A	A) 开关电源; B) 线性电源 A) Switching power supply; B) Linear power supply
输出电压 Output Voltage	V	24	
额定功率 Total Rated Power	W	75	
效率 Efficiency	%	88	230Vac/50Hz, 额定负载, 0.5h后测试 Run the test after 0.5 hours at full load
功率因数校正 Power Factor Correction		C	A) 主动式 active PFC; B) 被动式 Passive PFC; C) 无 No
纹波&噪声 Ripple Noise	mVp-p	100	详见备注 See remarks
产品认证标志 Product Certification Mark		0	0 无、1 CE、2 CCC、3 CQC、4 TUV、5 UL、6 CB、7 TUVul、8 CSA、 9 FCC、10 KC、11 GL、12 ATEX、13 IECEX、14 CUL、15 其它 others

1. 输出纹波噪声测试条件/DC output ripple & noise test conditions:

1) 示波器须设置在 20M 赫兹带宽/Oscilloscope should be limited at 20MHZ bandwidth;

2) 将 0.1uF 的陶瓷电容和 47uF 的电解电容并联在线材末端/ Connect 0.1uF ceramic capacitors and 47uF electrolytic capacitors in parallel at the end of the wire;

3) 使用 300mm 的双绞线连接电源和负载/ Connect the load and power supply with a 300mm twisted pair;

4) 在负载端进行测试/ Test on the load side;

5) 若无特殊说明, 以上规格参数均在输入电压范围为 90~264Vac, 温度范围 25°C 的环境下测量。/ Unless otherwise specified, the above specifications are measured in the input voltage range of 90~264Vac and the temperature range of 25 °C.

2. "0": 不符合项 " / " : Non-conformance term;

输入特性: Input Characteristics:

项目 Item	单位 Unit	最小值 Min	额定值 Rated	最大值 Max	备注 Notes
输入电压类型 Input Voltage Type			B+D		A) 三相供电; B) 单相供电; C) 双相供电; D) 直流供电; E) 其它不规则供电 A) Three-phase; B) Single-phase; C) Dual phase; D) DC power supply; E) Other power supply
输入电压 Input Voltage	Vac	90	115/230	264	参考输出降额曲线 Refer to output derating curve.
	Vdc	120		370	
输入频率 Input Frequency	Hz	47	50	63	
输入电流 Input Current	A			0.75	230Vac 满载 Full load
				1.30	115Vac, 满载 Full load.
输入冲击电流 Inrush Current	A			30	230Vac, 满载, 冷机启动 Full load. cold start.
输入冲击电流方案 Inrush Current Mode			B		A) 主动式 Active; B) 被动式 Passive; C) 单电阻 Only Resistance; D) 无 NO
空载损耗 No-Load Consumption	W			1	230Vac, 空载 No load @ Vout=24V
输入保险 Input Fuse					T4A/250Vac

" / " : 不符合项 " / " : Non-conformance term;

输出特性: Output Characteristics:

项目 Item	单位 Unit	最小值 Min	典型值 Typ	最大值 Max	备注 Notes
标准输出电压 Output Voltage	Vdc		24		
输出电压可调范围 Output Voltage Adjustable Range	Vdc	24		28	
额定输出电流 Rated Output Current	A	0		3.2	@24V输出 Output@24V
负载调整率 Load Regulation	%	/	/	+/-1	230Vac, 0% ~ 100% load 最小负载到额定负载 Min load to rated load
输入电压调整率 Line Regulation	%			+/-0.5	85~264Vac 额定负载 Rated load
温度调整率 Temperature Regulation	%			+/-0.07	+/-0.07% @ 0°C~+60°C; +/-1% @ -25°C~0°C&+60°C~+70°C; +/-2.5% @ -40°C~-25°C;
电压误差 Voltage Tolerance	%			+/-2	-25°C~+70°C
开机延迟时间 Setup Time	s			2	115Vac&230Vac 100% Load 额定负载 Rated load
上升时间 Rise Time	ms			100	输出从10%上升到90%的时间 The time taken while output voltage increased from 10% to 90%
保持时间 Hold Up Time	ms	15			115Vac, 满载 Full load
	ms	20			230Vac, 满载 Full load
过冲响应 Overshoot Response (O/P Voltage)	%			+/-5	开关机时 Power on/off
负载动态 Load Dynamic Response	%			+/-5	设定周期20ms, 升降电流0.1A/μs, 在10%~90%负载 Setting period 20ms. Rising and falling current 0.1A/μs@ 10%~90% load
并联冗余功能 Parallel Connection					详见附件 See Appendix

“?”：不符合项 “/”：Non-conformance term;

环境特性 Environment Characteristics

项目 Item	单位 Unit	最小值 Min	典型值 Rated	最大值 Max	备注 Notes
温度 Temperature	°C	-20	25	70	工作温度 Operation Temperature; 50°C~70°C以上需降额使用, 参考降额曲线; -40°C启动; Derated@50°C~70°C, refer to derating curve; Start up@-40°C
		-40	25	85	贮藏温度 Storage Temperature
相对湿度 Humidity	RH	5%		95%	工作湿度 Operation Humidity
		5%		95%	贮藏湿度 Storage Humidity
振动 Vibration		幅度<15Hz, ±2.5mm (IEC 60068-2-6) /15Hz..150Hz, 0.7G, 90分钟 < 15Hz, amplitude ±2.5mm(acc. to IEC 60068-2-6) / 15Hz ... 150Hz, 0.7G, 90 min.			
冲击 Impact		30G, 各个方向 (IEC 60068-2-27) 30G, each direction(acc. to IEC 60068-2-27)			
海拔高度 Altitude		≤3000m, 3000m以上降额使用, 15%load/Km, 最高海拔5000m ≤3000m, derated over 3000m, 15% load/Km, max altitude 5000m			
冷却方式 Cooling Mode		空气自然冷却 Air Cooling			

防护等级 IP Level	IP20
污染等级 Pollution Level	PD2
RoHS环境指令	符合Compliant
阻燃等级 (外壳) Flame Rating(Case)	UL94V-0

“/”：不符合项 “/”：Non-conformance term;

保护功能 Protection Function

项目 Item	技术要求 Technical Requirement	恢复方式 Recovery Mode	保护方式 Protection Mode	备注 Notes
输出短路保护 Output Short Circuit Protection	电源无损坏, 关闭输出电压 Power supply no damaged, shut down O/P voltage.	C	C	恢复方式Recovery mode: A) 自动恢复Auto recovers; B) 重启恢复Restart; C) 打嗝Hiccup 保护方式Protection mode: A) 恒功率Constant power; B) 恒电流Constant current; C) 输出掉电Output voltage drop;
输出过流保护 Output Over Current Protection	110%~150% @ Io	C	C	
输出过压保护 Output Over Voltage Protection	120~150% @ Vo	C	C	
过温保护 Over Temperature Protection	关闭输出电压 Shut Down O/P Voltage.	C	C	

“/”：不符合项 “/”：Non-conformance term;

特殊功能 Specific Function

项目 Item	技术要求 Technical Requirement
面板显示 Panel Display	当输出指标正常时, 绿色LED常亮/Output Voltage \geq 21.6V, Green LED is always on;

“/”：不符合项 “/”：Non-conformance term;

电气安全 Electrical Safety

项目 Item	测试方法 Test Method	测试条件 Test Conditions	备注 Notes
高压测试 Hi-pot Test	输入-输出 I/P-O/P	4242Vdc. 60s, \leq 1mA	
	输入-大地 I/P-PE	2121Vdc. 60s, \leq 1mA	
	输出-大地 O/P-PE	700Vdc. 60s, \leq 1mA	
绝缘阻抗 Withstand Resistance	输入-输出 I/P-O/P		500VDC. \geq 5M Ω
	输入-大地 I/P-PE		500VDC. \geq 5M Ω
	输出-大地 O/P-PE		500VDC. \geq 5M Ω
泄露电流	L、N-外壳/L、N-Case		3.5mA Max

Leakage Current	L、N-PE/L、N-PE	3.5mA Max
接地阻抗 PE Resistance	PE-外壳/PE-Case	< 0.1Ohm
过电压等级 Overvoltage category	III, II	III (IEC 61010-1, IEC 61010-2-201, EN 62368-1, EN 61558-2-16) II (EN 62368-1, EN 60335-1)
电气设备安全等级类属 Electrical Equipment Safety Class	A	A)一类设备Class I ;B)二类设备Class II;C)三类设备 (最高标称电压不超过50Vac或120VDC, 以及不属于AB) Class III(The maximum nominal voltage does not exceed 50Vac or 120VDC, and is not part of A,B); EN 61140, GB/T17045
安规标准 Safety Standard		EN62368-1, GB4943.1
		EN61010, GB4793.1

1) “/”: 不符合项 /“Non-conformance;

电磁兼容 Electromagnetic Compatibility

项目 Item	测试标准 Test Standard	测试条件 Test Conditions
静电ESD Electrostatic Discharge	IEC 61000-4-2 GB17626-2	Criteria A; Air Discharge: ±8kV; Contact Discharge: ±4kV
射频辐射RS Radiated Field	IEC 61000-4-3 GB17626-3	Criteria A; 80-1000MHz, 10V/M, 80% modulation (1kHz);
脉冲杂讯EFT Electrical Fast Transient / Burst	IEC 61000-4-4 GB17626-4	Criteria A; ±4kV
雷击 Surge	IEC 61000-4-5 GB17626-5	Criteria A; Common Mode: 4kV; Differential Mode: 2kV
射频传导 Conducted Emission	IEC 61000-4-6 GB17626-6	Criteria A; 0.15-80MHz, 10Vrms, 80% modulation (1kHz) 80MHz-1GHz, 10Vrms, 80% modulation (1kHz) 1.4GHz-2GHz, 10Vrms, 80% modulation (1kHz) 2GHz-2.7GHz, 10Vrms, 80% modulation (1kHz)
电压瞬断 Voltage Dips And Interruptions	IEC 61000-4-11 GB17626-11	Voltage Dips >95% reduction,0.5 period Criteria A
		Voltage Dips >30% reduction,25 period Criteria B
		Voltage interruptions >95% reduction,250 period Criteria B
谐波 Harmonic Current Emission	IEC/EN 61000-3-2 GB17625-1	Class A
传导和辐射通用标准 CE&RE	GB9254, CISPR 32, EN 55032 Class B	GB9254, CISPR 32, EN 55032 Class B
电压波动和闪烁 Voltage Fluctuation and Flicker	IEC/EN 61000-3-3, GB17625.2	Criteria B

- 标准A: 规格界限内正常性能Criteria A: Normal performance within the specification limits;
- 标准B: 可自行恢复的临时性退化或功能丧失Criteria B: Temporary degradation or loss of function which is self-recoverable;
- 标准C: 不可自行恢复的临时性退化或功能丧失, 必须重新启动后才能恢复正常工作Criteria C:Need to restart the power supply, to return to normal work;
- 标准D: 永久性退化或功能丧失, 需要更换零部件或维修人员介入Criteria D:Permanent degeneration or loss of function;
- 不对称: 共模 (线对地) Asymmetrical: Common mode (Line to earth);
- 对称: 差模 (线对线) Symmetrical: Differential mode (Line to line);
- 电源应视为系统内元件的一部分, 需结合终端设备进行EMC确认Power should be considered part of the element within the system, to be combined with the terminal device EMC acknowledgment;

可靠性数据 Reliability

项目 Item	数据 Data	测试条件 Test Conditions
------------	------------	-------------------------

产品老化 Burn-in	100%	230Vac, 满载Full load, 40°C±5°C, 4小时Hours
平均无故障时间 MTBF	200000H Min	230Vac, 满载Full load, 25°C, MIL HDBK 217F

“/”: 不符合项 “/”Non-conformance;

结构与安装 Mechanical Installation

项目 Item	数据 Data	备注 Note
尺寸mm (长宽高) Size	127 * 115* 35	材质: 铝; Case material: AL
重量Kg Weight	0.48	
安装方式 Installation	导轨式安装 Mounted On 35mm DIN Rails	TS-35/7.5或TS-35/15 EN 60715
最小间距 Space	上下(Above/Below): 45mm; 左右(Left and right side): 0mm,5mm With a Heat Source	
输出端子 Output Terminal	脚距7.5mm, 4位/Pitch=5mm, 4pin	直插式连接Push-In Terminal;
	1 PIN---V+	硬导线横截面Hard wire cross section 0.2 mm ² ... 4 mm ² ;
	2 PIN---V+	柔性导线横截面Flexible wire cross section 0.2 mm ² ... 2.5 mm ²
	3 PIN---V-	横截面Cross section AWG 24 ... 12
输入端子 Input Terminal	脚距7.5mm, 3位Pitch=7.5mm, 3pin	直插式连接Push-In Terminal;
	7 PIN---L	硬导线横截面Hard wire cross section 0.2 mm ² ... 4 mm ² ;
	8 PIN---N	柔性导线横截面Flexible wire cross section 0.2 mm ² ... 2.5 mm ²
	9 PIN---FG	横截面Cross section AWG 24 ... 12 剥线长度Strip length 10 mm

框架图 Block diagram

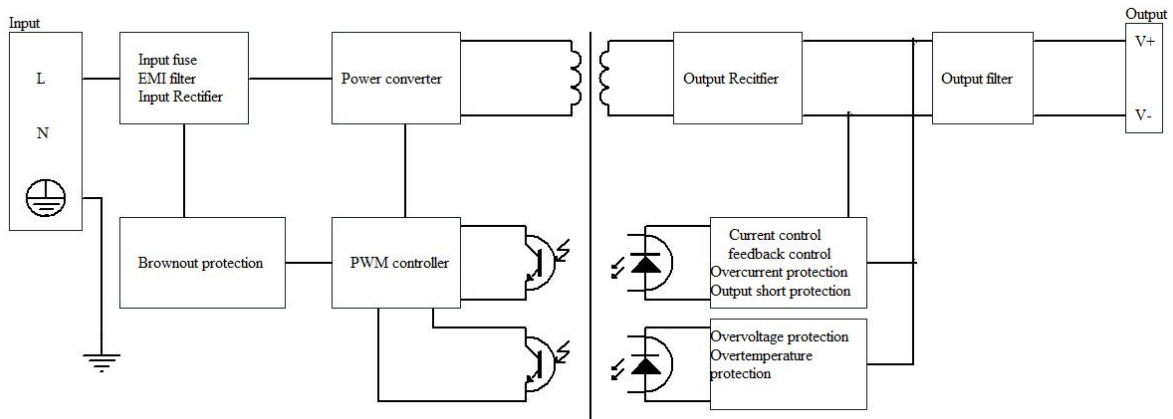

附件 (安装示意图、降额曲线、典型应用、导轨安装方法)

Appendix(Installation Instruction /Derating Curve/Typical Application/Din-rail Installation Method)

1. 产品装配示意图 Product assembly

说明:

Note:

A: 产品名称特性示意, 具体参数依照规格书。

A: Refer to product specifications.

B: 建议扭矩: M3.0 螺钉 < 0.4 N · m; M4.0 螺钉 < 0.6 N · m。

B: Suggested tightening torque: M3.0 screw < 0.4 N · m; M4.0 screw < 0.6 N · m.



Install rail / 安装轨道: TS35/7.5 or TS35/15

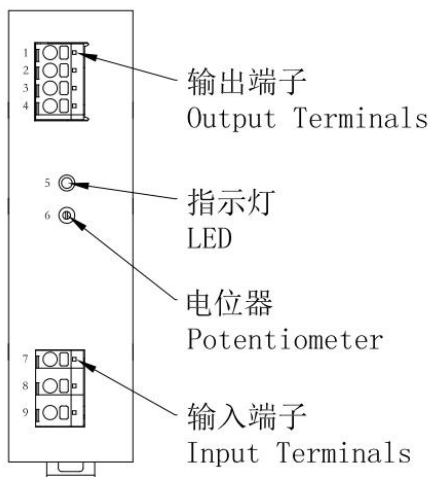
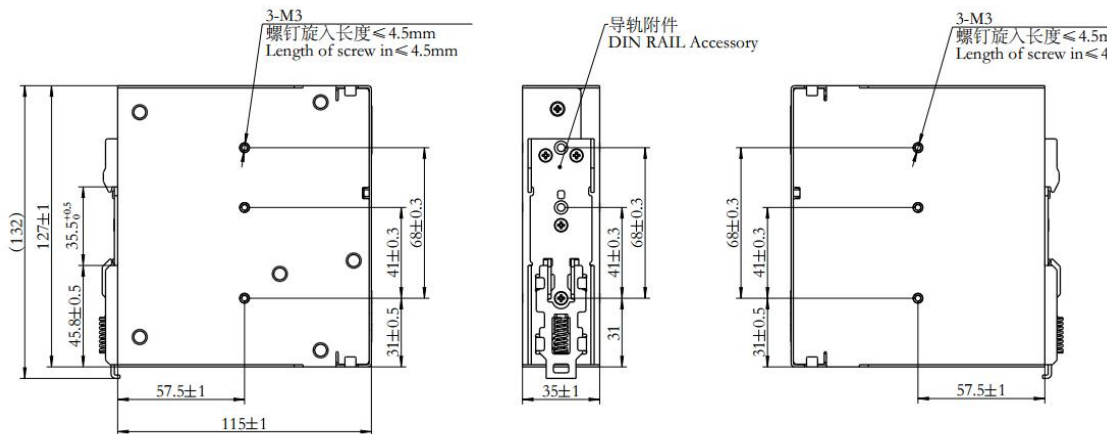

1	输出+
2	输出+
3	输出-
4	输出-
5	LED指示灯
6	电位器
7	AC(L)
8	AC(N)
9	PE

2. 降额曲线 Derating Curve:



图1：输出电压下输出电流降额曲线
Fig1: Output Current Derating curve depending on Output Voltage



图2：环境温度和输入电压下输出功率降额曲线
Fig2: Output Power Derating curve depending on Ambient Temperature and Input Voltage

3. 限流特性 Current Limiting Characteristic

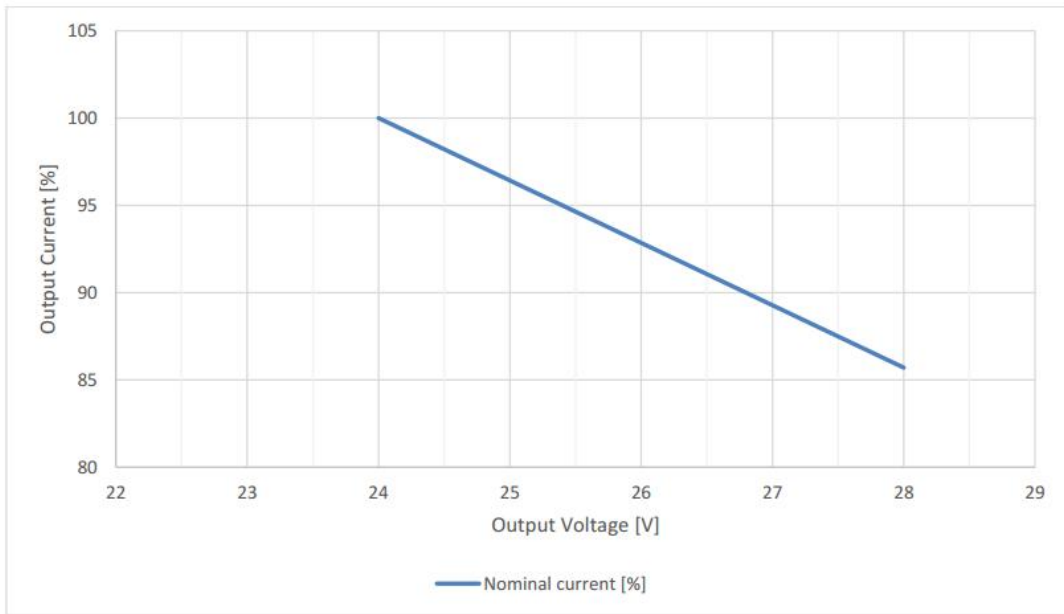

4. 典型应用 Typical Application :

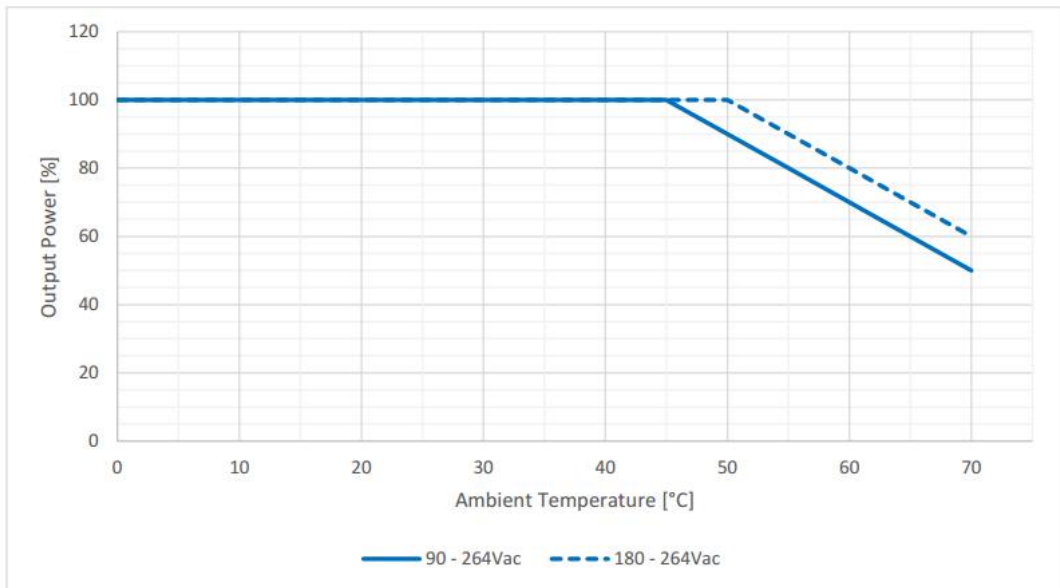
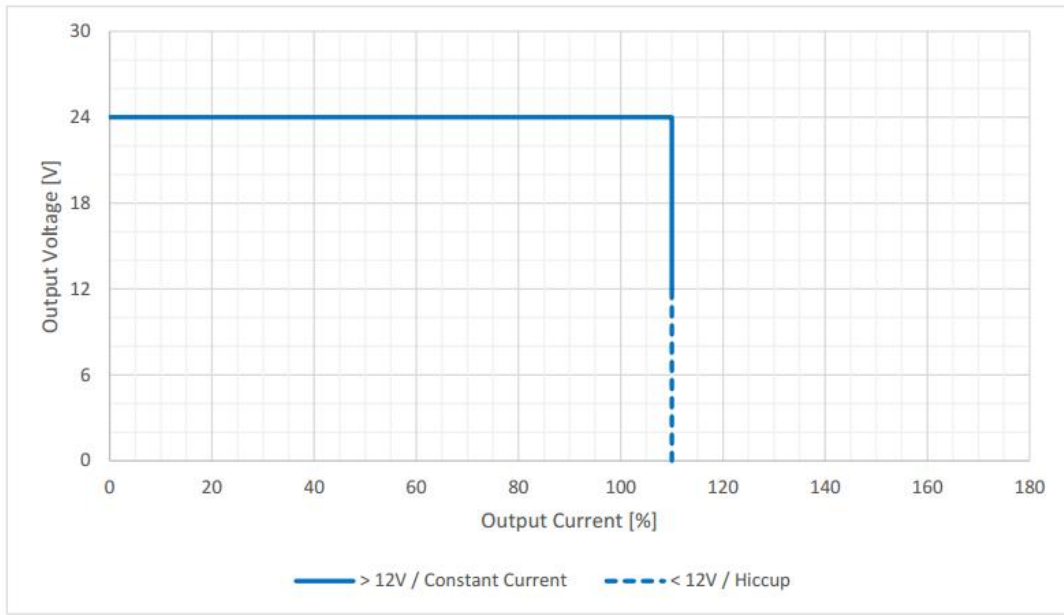
3.1 串联接线图 Series Operation Connection Diagram :

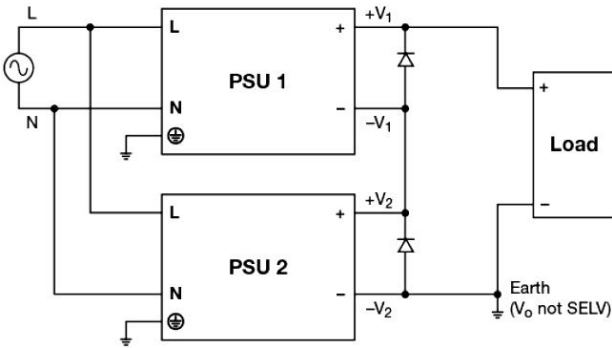

3.2 1+1 冗余接线图 1+1 Redundancy Connection Diagram

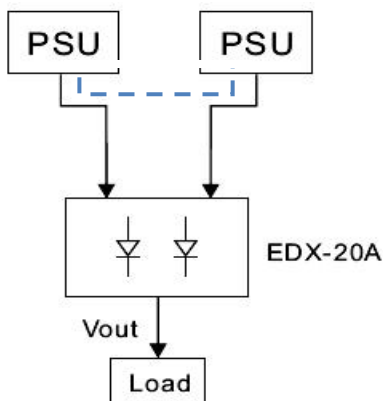

3.3 1+N 冗余接线图 1+N Redundancy Connection Diagram:

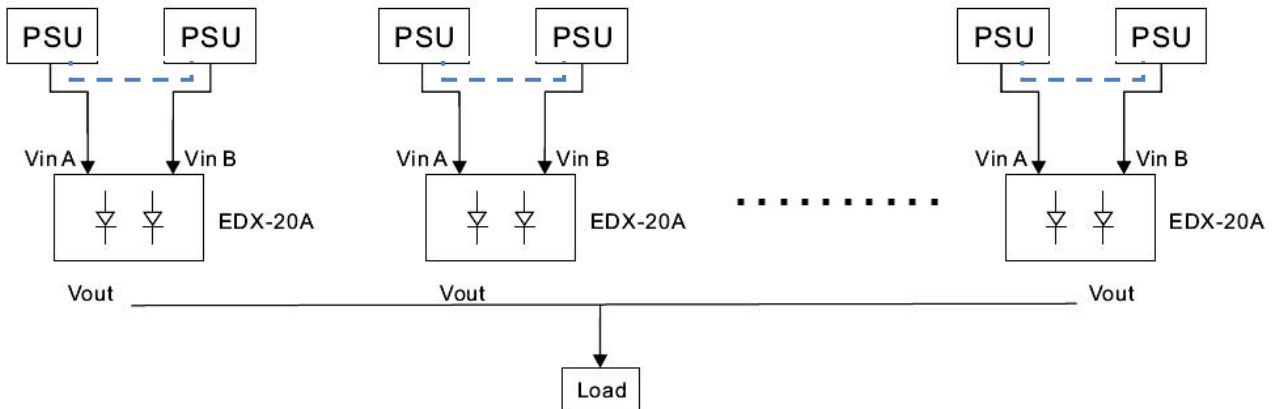

3.4 可靠性系统构建图 Reliability system:

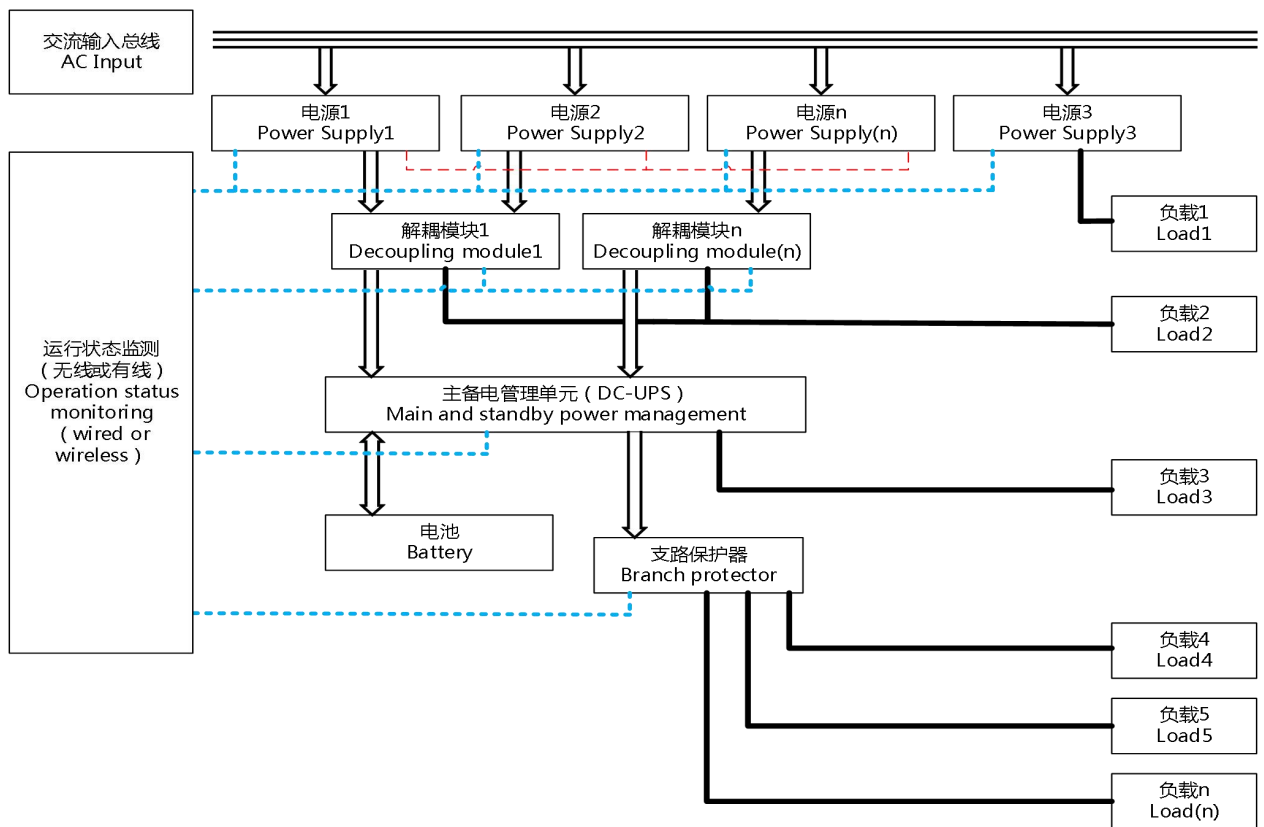

5. 导轨安装方法 Din Track Mounting:

- (1) To mount the Block on a DI track, hook portion (A) of the Block onto the track and press the Block in direction (B).
- 安装：将(A)部分挂入导轨，朝(B)方向按压卡入导轨

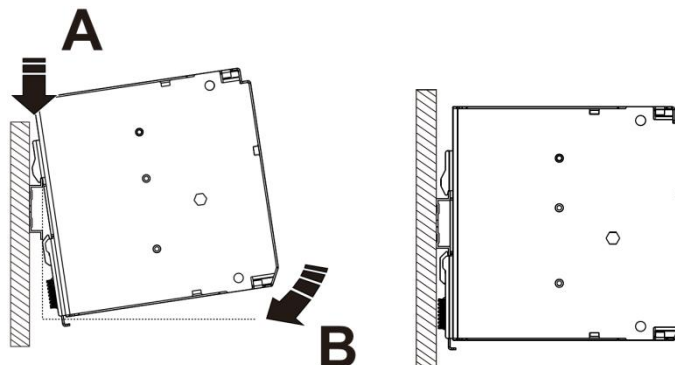

(2) To dismount the Block, pull down portion (C) with a flat-blade screw-driver and pull out the Block.
 拆卸：用平口螺丝刀下拉 (C) 部分拆卸电源

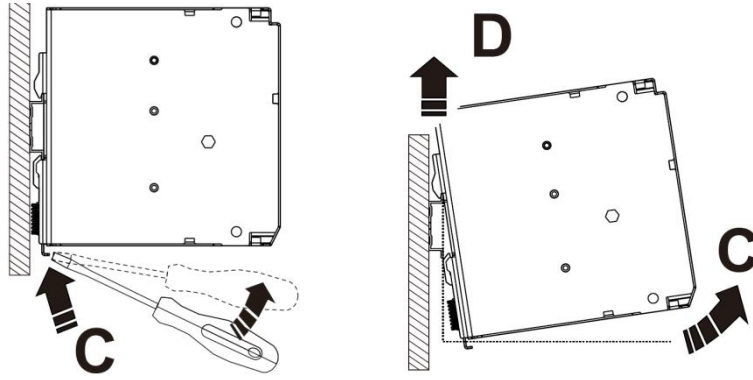

(3) 通用壁挂式安装图 Mounting the universal wall adapter

